

90° BI-PARTING CAVITY SLIDER - SQUARE SET TYPE T90

FOR TIMBER DOOR

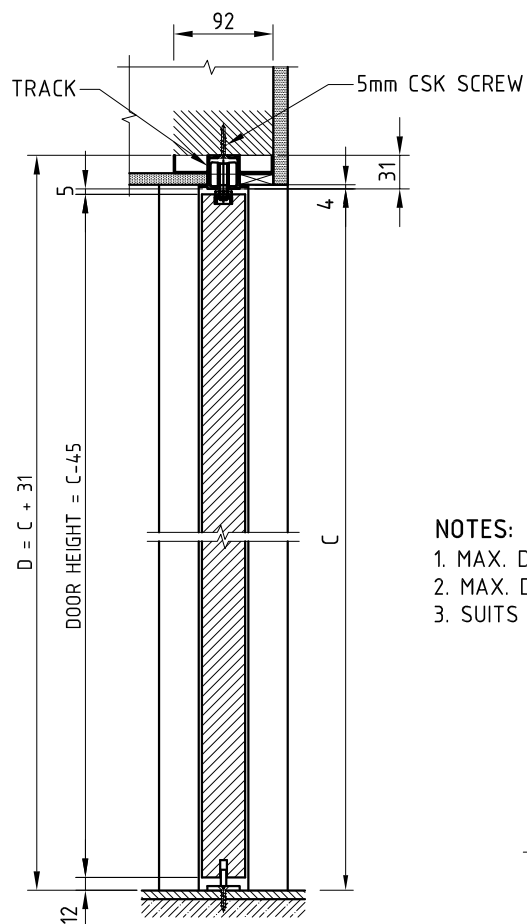

SECTION A - A

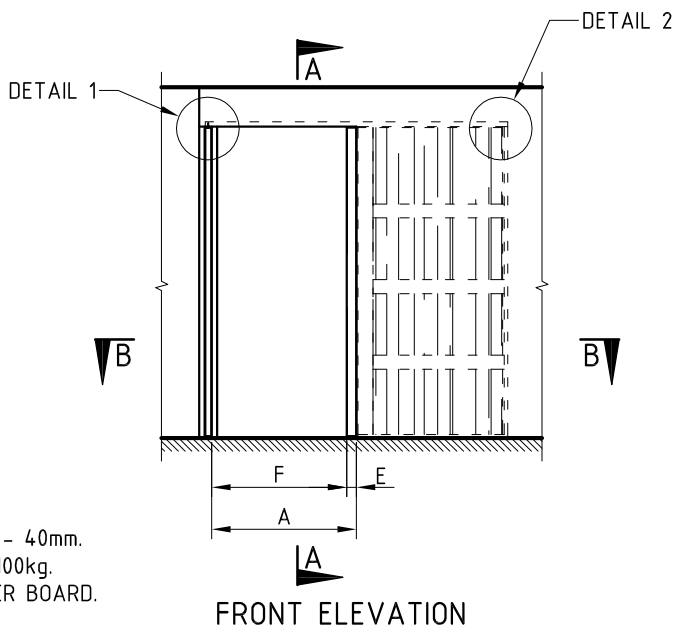

FRONT ELEVATION

- NOTES:**
1. MAX. DOOR THICKNESS - 40mm.
 2. MAX. DOOR WEIGHT - 100kg.
 3. SUITS 10-13mm PLASTER BOARD.

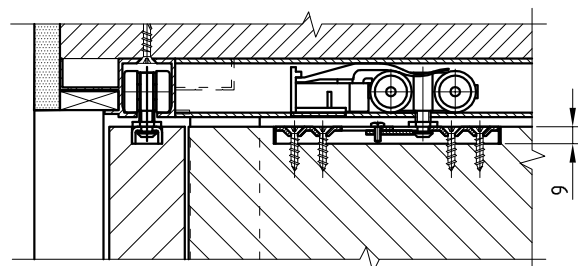

DETAIL 1

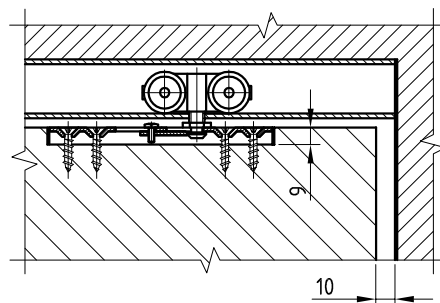

DETAIL 2

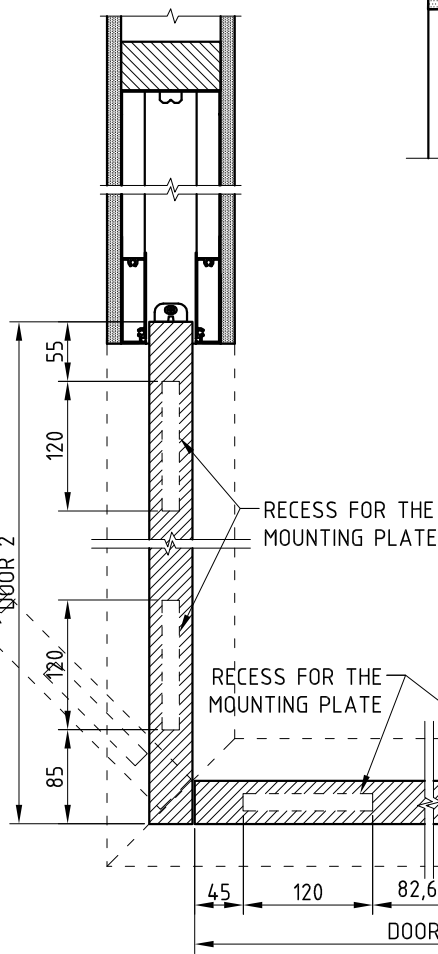
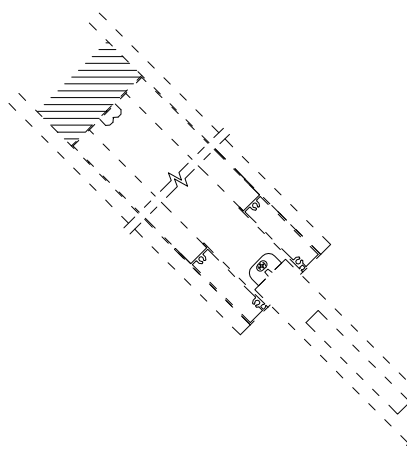

SECTION B - B

RUBBER BUMPER

ALUMINIUM FRAME

- A - OPENING FRAME WIDTH.
 C - DISTANCE FROM FINISHED FLOOR TO UNDERSIDE OF TRACK.
 D - DISTANCE FROM FINISHED FLOOR TO UNDERSIDE OF SUPPORT BEAM.
 E - PROJECTION OF DOOR FROM CAVITY.
 F - CLEAR OPENING WIDTH.