

90° BI-PARTING CAVITY SLIDER - SQUARE SET TYPE T80 FOR TIMBER DOOR

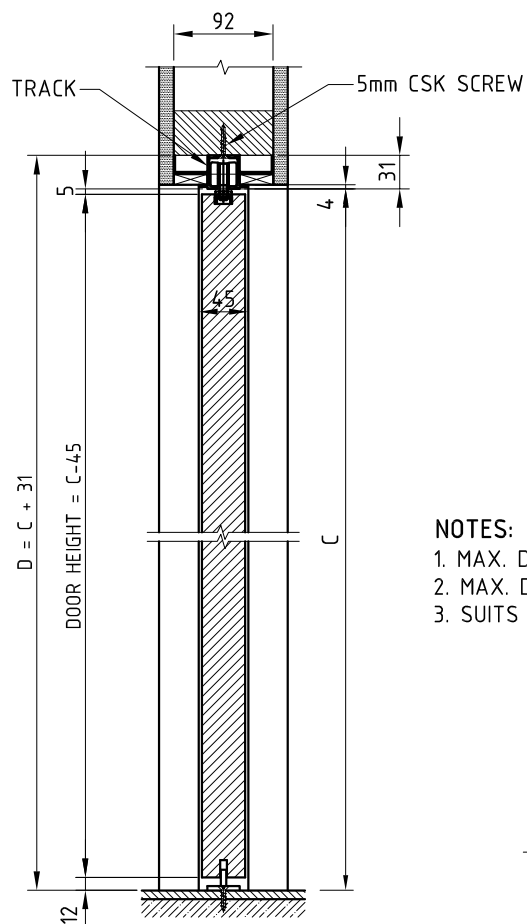

SECTION A - A

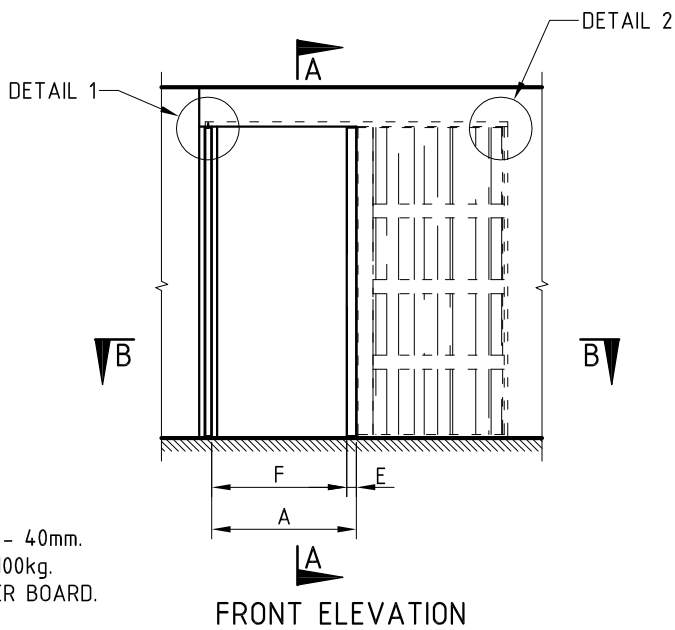

FRONT ELEVATION

- NOTES:**
1. MAX. DOOR THICKNESS - 40mm.
 2. MAX. DOOR WEIGHT - 100kg.
 3. SUITS 10-13mm PLASTER BOARD.

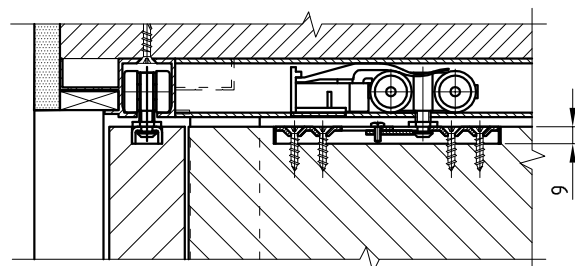

DETAIL 1

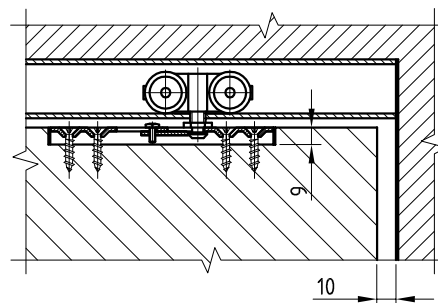

DETAIL 2

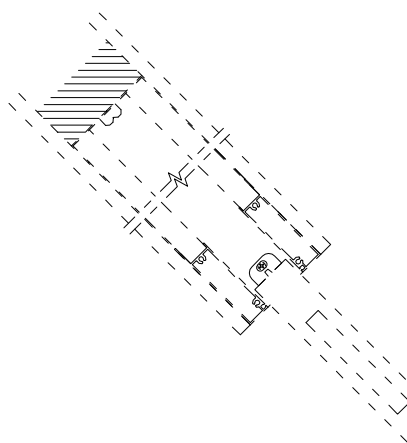

SECTION B - B

- A - OPENING FRAME WIDTH.
- C - DISTANCE FROM FINISHED FLOOR TO UNDERSIDE OF TRACK.
- D - DISTANCE FROM FINISHED FLOOR TO UNDERSIDE OF SUPPORT BEAM.
- E - PROJECTION OF DOOR FROM CAVITY.
- F - CLEAR OPENING WIDTH.

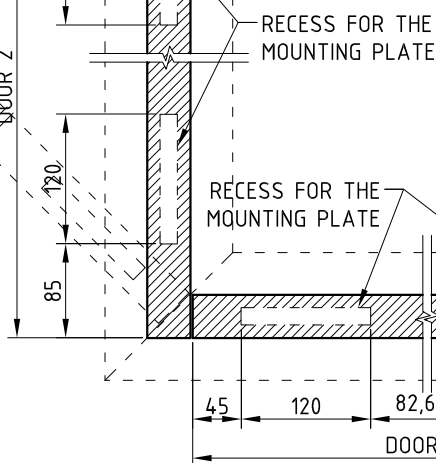

RUBBER BUMPER

ALUMINIUM FRAME